



CST 82 BODY SPECIFICATIONS

Standard Construction

- Bulkhead (non-ribbed) 14 ga. galvaneal steel
- Crossmember-front 7 ga. hot-rolled formed channels
- Crossmember-intermediate 12 ga. galvaneal steel
- Crossmember-rear 7 ga. hot-rolled formed channels
- Compartment Bottoms 16 ga. galvaneal steel
- Compartment Tops 14 ga. galvaneal steel (one-piece integral w/loadspace centers)
- Doors 16 ga. galvaneal steel double panel
- End panels-front 14 ga. galvaneal steel
- End panels-rear 14 ga. galvaneal steel
- Fender panels 16 ga. galvaneal steel
- Floor 12 ga. embossed galvaneal treadplate
- Loadspace inside centers 14 ga. galvaneal steel (one-piece integral w/compartment tops)
- Intermediate panels 16 ga. galvaneal steel
- Longitudinals 10 ga. galvaneal formed
- Shelving 14 ga. high-spangle galvanized (250 lb. static load cap.)
- Tailgate 16 ga. galvaneal (double panel, formed construction)
- A-40 galvaneal construction. Two-sided zinc coated galvaneal (.40 oz. zinc coating per square foot of steel) provides maximum rust and corrosion resistance.
- Body sides are constructed using plated lock-bolt fasteners.
- Floor understructure rigidly welded for structural integrity and durability. Mounting points reinforced w/U-channel gussets.



Body pictured with optional Recessed Punched Bumper with surface-mounted LED 3-in-1 Light Kit and Aluminum Fuel Fill

Covered by STAHL's



CST 82 STANDARD FEATURES

For Customer Service Call:
1.800.277.8245
stahltruckbodies.com/contact

Construction – Lock-bolt to provide unbeatable durability, eliminates rust-causing welding and grinding, and promotes corrosion-free, long-lasting product. Floor understructure rigidly welded for structural integrity and undercoated for superior rust protection.

Compartment Tops – Smooth seamless surface to enhance appearance.

Cutouts – Openings in intermediate panels between horizontal and adjacent vertical compartments provides extended storage between compartments.

Door Hinges – Concealed, bolt-on style provides increased security and clean appearance

Door Latches – Bolt-on rotary style with stainless steel paddle handles and stainless steel pans.

Lock Cylinders – are keyed alike with double-bitted keys and are power door lock ready for easy after-market installation.

Door Striker – Adjustable, bolt-on.

Horizontal Doors – Use vinyl coated aircraft quality cables for support in open position.

Automotive Style Door Seal – STAHL-engineered clip-on to allow easy removal for painting, replacement and quicker installation. Door seals against a flat surface for extra protection against water leakage.

Drip Rail – Concealed to provide extra protection against water leakage.

Fender Panel Kits – Bolt-on die-stamped with radius wheel opening.

Tailgate – Two point slam-locking featuring anti-rack/rattle hardware.

Compartment Trays – Bolt-in material trays with dividers.

Powder Coat Finish – Body exterior, compartment interiors, and cargo area surfaces are finished in a durable, corrosion resistant white powder coat.

Undercoating – On bottom of floor and wheel wells.

Compartment Layout*

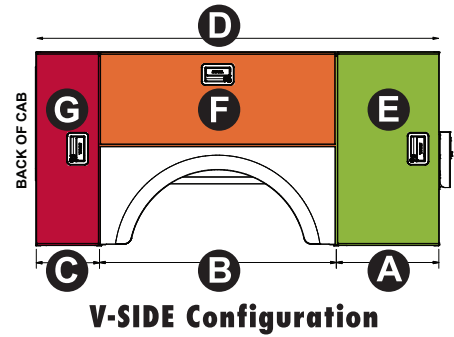
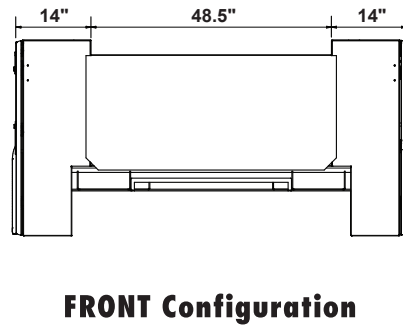
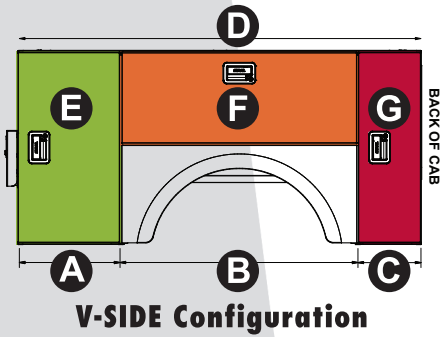

*Side compartment overall height is 39.57"

Dimensional Data

Single Rear Wheel (SRW) – "V-Side" Compartment Dimensions

MODEL	APPROX. WT.	CAB-TO-AXLE	A	B	C	D	COMPARTMENT CLEAR DOOR OPENINGS		
							E	F	G
CST82VVS	910 lbs.	37", 40", 42"	21.41"	47.19"	13.41"	82"	17.34" x 36.37"	45.31" x 14.94"	9.06" x 36.37"

Compartmental Tray Configurations

CST82 (V-Side Configurations)

COMPARTMENT	CURBSIDE COMPARTMENTATION	STREETSIDE COMPARTMENTATION
Front Vertical	(1) adjustable tray with dividers	(1) adjustable tray with dividers
Horizontal	(1) adjustable tray with dividers	Open
Rear Vertical	(2) adjustable trays with dividers	(2) adjustable trays with dividers

For other CST82 models and dimensional data visit our website: stahltruckbodies.com/CST

OPTIONAL FEATURES

- Amber Strobe Light Kits
- Back Up Alarms
- Bar Lock (Master Locking Sys.)
- Bumpers
- Compartment Strip Light Kits – LED
- Drawer Packages
- Folding Steps & Grab Handles
- Fuel Fill (Alum.)
- Headache Racks (Cab Guards)
- High Roof Enclosures
- Hitches & Hooks
- Ladder Racks
- Light Kits – LED
- Louver Vents
- Low Sliding Roof
- Off-Road Mounting Kits
- Paint and Primer
- Pipe Carrier
- Power Door Locks
- RHINO Liner
- Tie-Down Rings
- Tire Carrier
- Top Paks (add-on)
- Trays with Dividers
- Treadbrite Overlay

Due to constant product evaluations and improvements, specifications are subject to change without notice.

STAHL / Scott Fetzer Company
 3201 W. Old Lincoln Way
 Wooster, OH 44691
 P: 800.277.8245 F: 330.264.0300
stahltruckbodies.com/CST

STAHL
 TRUCK BODIES & CRANES